

REEEP GROUP SDN. BHD.

Company No.: 201001036703 (920626-D)

RENEWABLE ENERGY & ENERGY EFFICIENCY PARTNERSHIP

Engineering Services, Contract & Project Management:-

- Renewable Energy
- Power Plant
- Oil & Gas
- Utility
- Industrial & Commercial



No. 3-21, Pusat Perdagangan KLH
Menara KLH, Bandar Puchong Jaya
47170 Puchong, Selangor, Malaysia.

E-mail Address: enquiry@reeepgroup.com

Website: www.reeepgroup.com

Contents

1

Introduction

2

Scope of Services

3

Management Team and Competent Person

4

Major Project Reference of The Team

5

Other Project Experience



1

Introduction

Company Policy - SAVEFUME - Q

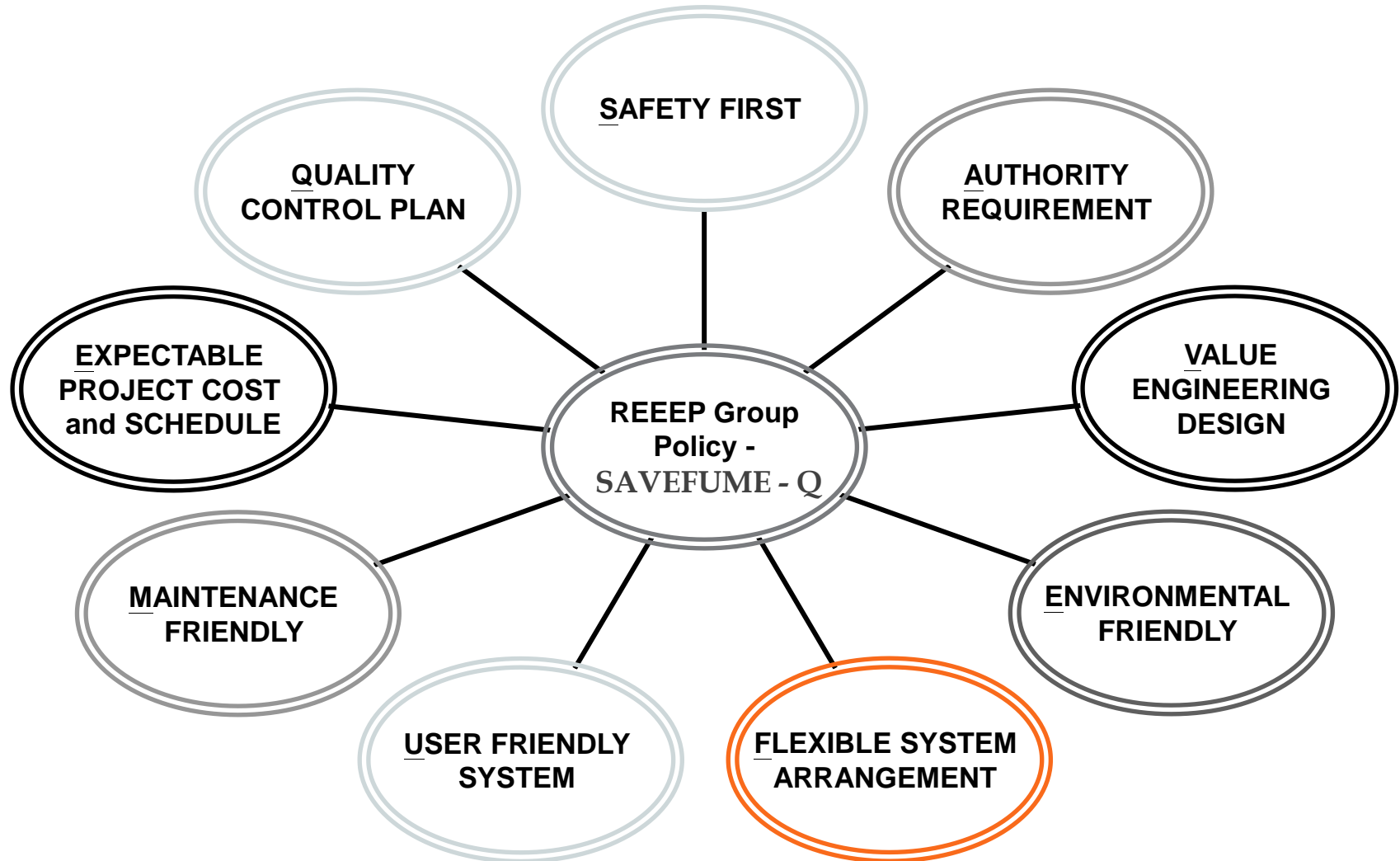

Company Brief



REEEP Group Sdn. Bhd. was incorporated on 2nd November 2010 by a group of energetic and experienced engineers. The group commits to provide a reliable, quality and safe work to clients.

REEEP is an acronym of **RENEWABLE ENERGY AND ENERGY EFFICIENCY PARTNERSHIP**. The company welcomes any corporation, company, energetic and experienced engineers to be partnering with us to form an integrated all-in-one business related with energy. The range of business includes product, system, project, engineering, installation & commissioning, training, operation and maintenance.

Licensed Electrical Service Contractor Governed by Messrs. Suruhanjaya Tenaga

ST(TKL)SGR/C/KPE/00130/2024
Suruhanjaya Tenaga

NO: 2024/02178

BORANG P
(peraturan 71)

AKTA BEKALAN ELEKTRIK 1990

PERAKUAN PENDAFTARAN SEBAGAI KONTRAKTOR PERKHIDMATAN ELEKTRIK

Mengikut peraturan 71 Peraturan-Peraturan Elektrik 1994, Perakuan ini dikeluarkan kepada

REEEP GROUP SDN. BHD.
(nama syarikat)

dan memberi kuasa kepada pemegang untuk menjalankan perniagaan perkhidmatan kejuruteraan elektrik sebagai Kontraktor Perkhidmatan Elektrik di :

NO. 3-21,
MENARA KLH,
47170 PUCHONG,
SELANGOR

(alamat perniagaan dan cawangan)

pada voltan pengendalian lebih kurang :

500	25	12	33	11	0.415
-----	----	----	----	----	-------

*kilovolt

selama tempoh 5 tahun** dari tarikh dikeluarkan yang ditunjukkan di bawah :

Tarikh dikeluarkan : 05/07/2024
Tarikh Habis Tempoh : 04/07/2029
No. Pendaftaran : ST(TKL)SGR/C/KPE/00130/2024
F I R M : 3,300.00

Ir. ZUL-AZRI BIN HAMIDON
Pengerah Kawasan
Suruhanjaya Tenaga
Kawasan Selangor & WP (KL & Putrajaya)

Suruhanjaya Tenaga

** Tidak kurang daripada satu tahun dan tidak lebih daripada lima tahun.

Member of The Electrical And Electronic Association of Malaysia



2024

Since 1952

THE ELECTRICAL AND ELECTRONICS ASSOCIATION OF MALAYSIA

This is to certify that

REEEP Group Sdn Bhd

is a member of

The Electrical and Electronics Association of Malaysia



Changye

President

Amy

Honorary Secretary

Membership No. : EC (C) 2496



2

Scope of Services

Business Activities:- Projects



- ❖ **Renewable Energy**

(Biogas & Photo-Voltaic Power Generation System, Solar Thermal Hot Water System, Steam System Optimization; Hydro, Biomass)

- ❖ **Power Plant**

(Power Generation System & Auxiliary Supply System)

- ❖ **Oil & Gas**

(Off Shore & Petrochemical Industries)

- ❖ **District Cooling Plant**

(Chiller System & Cogeneration Plant)

- ❖ **Utilities**

(Switchyard, Substation & Water Treatment Plant)

- ❖ **Industrial**

(Steel Mills, Palm Oil Mills, Paper Mills, Food Industries, Chemical Industries, Electrical & Electronic Industries, Automobile Industries & etc)

- ❖ **Commercial**

(Hospitals, High Rise Buildings, Shopping Complex, Theme Parks & etc)

Scope of Services:- System

- ❖ **Electrical Generation System**
(Gas Turbine Generator, Steam Turbine Generator, Hydro Turbine Generator, Diesel Generator & UPS System)
- ❖ **Electrical Distribution System**
(Switchyard, Substation, Switchgear, Transformer, Bus-duct, Switchboards, SCADA System, DC Control Wiring, DC Battery and Charger System, Sub-main Cable, Distribution Board, Metering System, Earthing System, Lighting Protection System)
- ❖ **Instrumentation and Control System**
(Distributed Control System, Field Instrument, Building Automation)
- ❖ **Energy Management**
(Power Management & Monitoring Systems)
- ❖ **Mechanical System**
(Air Conditioning and Ventilation, Chiller Plant, Water Supply, Fire Protection, Steam, Lifts & Elevator and Compressed Air Systems)
- ❖ **Boiler, Unfired Pressure Vessel and its auxiliaries**
- ❖ **Compressed Air System & Low Pressure Blower Fan**
- ❖ **Process System Optimization - Energy Recovery / Energy Efficiency**
(Steam System, Steam Sub-system, Hot Water System, Hot Air System, Waste Energy Recovery)

Scope of Services:- Range

- ✓ **Investment Support**
Due Diligent Technical Studies and Commercial Studies, Feasibility Studies, Front End Engineering Studies, Tender Document Preparation
- ✓ **Engineering**
Detail Engineering Studies, Design, Operation Philosophy, Technical Specification,,
Network Simulation Studies, Project Management, Technical Audits.
- ✓ **Installation & Commissioning**
Construction Work, HV & MV Switchgears, Transformers, Generators, LV Switchboards, Sub-circuits, Boiler fabrication, refurbishment and installation, pump, rotating equipment (fan and air heater) switch, Competent Person and Skilled Workers,
- ✓ **Operation & Maintenance Support**
Troubleshooting & Retrofit, Preventive Maintenance, Safety Management Plan Development, Plant Operation Development, Plant Turn Around Planning and Support
Steam Turbine Overhaul, Balancing of STG, Overhaul Large Motors, Vibration Analysis, pump, rotating equipment (fan and air heater) switch;
- ✓ **Testing & Supervising**
Supervising Installations, Protection Relay Coordination, Testing & Calibration.
- ✓ **Training**
- ✓ **Plant Improvement**
Failure Root Cause Assessment, Plant Audit, System Audit, Reliability Audit, Management Audit

Products:-



- ❖ Testing Equipment
(Relay Test Sets, Electrical Testing Equipment, Power Quality Analyzer)
- ❖ Energy Management
(HVAC Control System, Scada, Power Management System)
- ❖ Energy Efficiency
(EMI Barrier with Energy Saving Feature, Variable Speed Drive, Voltage Optimizers, Power Factor Correction System, Harmonic Compensators)
- ❖ Power Generation
(Gas Turbine Generators, Steam Turbine Generators, Diesel Generators, Auxiliary Systems)
- ❖ Power Distribution
(High Voltage & Low Voltage Circuit Breakers, Switchgears, Transformers, Cables, Measuring Devices, Control Components, Manual Motor Starters, Electrical Switchboard); Supply, installation and maintenance of electrostatic precipitator; Supply of boiler parts and cold bending of boiler tube, coil element and economizer

Scope of Services – Energy

- ❖ **Efficient Management of Electrical Energy Regulation 2008**
Reg. Electrical Energy Manager, Conduct EE Audit, Establish EE Policy, Provide EE Improvement Solution, EE Incentive Application, Project Finance Funding Arrangement
- ❖ **Electrical Bill**
Re-configure Plant/Building Process Operation Sequence to Save Maximum Demand Charge
- ❖ **Electrical Network**
Provide Recommendation for the Network Enrichment
- ❖ **Electrical Protection/Cable/Circuit Breaker/Earthing/Lightning Protection Scheme**
Provide Risk/Load Assessment Report and Recommendation
- ❖ **Substation/Transformer Yard**
Provide Recommendation for Heat Transfer Issue
- ❖ **Power Quality**
Conduct Plant/Building Power Quality Measurement to Overcome Nuisance Tripping Problem, Electr
- ❖ **Motor/Lift/Escalator/Conveyor**
Provide Recommendation for the best of Motor Starter Scheme, Review Economic Impact of Motor Efficiency versus Loading

Scope of Services – Energy



- ❖ **Transformer**
Review Economic Impact of Transformer Loading versus Losses
- ❖ **Air-Conditioning/Plant Process System (Including Boiler)**
Assess System Efficiency, Recommend Energy Efficiency Improvement
- ❖ **Utility/Water/Chemical/Lighting**
Assess Usage/Environmental Impact; Provide Alternative Solution
- ❖ **Building Material/Window/Roof/Ceiling/Carpet**
Assess (Energy Impact) Installed Material, Recommend Energy Efficiency Improvement



3

Management Team and Competent Person

MANAGING DIRECTOR



Nationality: Malaysian

Achievements:

- National Solar Thermal Technology Expert (UNIDO-GEF Project)
- National Steam System Optimization Expert (UNIDO-GEF Project)
- Grid-Connected Photovoltaic System Designer, SEDA, ISPQ
- ISO 50001 Energy Management System Auditor, Bureau Veritas
- Electrical Energy Manager - Energy Commission, 12 Oct 2010
- GBI Facilitator - Greenbuildingindex Sdn Bhd , 21 Sept 2010
- Competent Electrical Service Engineer - Energy Commission, 2023 ❖
- Competent Electrical Engineer - Energy Commission, 2007
- ASEAN Engineer - The AFEO, 20 April 2002
- Professional Engineer - Board of Engineers Malaysia, 2001
- Member of The Institution of Engineers Malaysia, 23 July 01
- Engineer Intern, State of Oklahoma, U.S.A.

Education: Oklahoma State University,

Degree: Bachelor of Science - July 1994

Major: Electrical Engineering & Computer Engineering

Name: Ir. TAN Kang Chu

(AVEFUME CONSULTANT – Principal)

Executive Summary:

- ❖ **Experience: 28 Years**
- ❖ **Discipline: Electrical Engineering Services**
- ❖ **Type of Project: Gas Exploration Platform, Oil & Gas Refinery Plant, Iron Ore Distribution Centre, Factory, Cogeneration / District Cooling Plant, Department Store, Hotel, Commercial Building and Housing Development.**
- ❖ **System: Generation (GENSET, GTG); Transmission (132 & 275kV system), Distribution System (~ 33kV), Control (PMS/ENMCS/SCADA); Building Service and Extra Low Voltage; Earthing System**
- ❖ **COGEN Projects: IOI Acidchem, PML; PFK; PPMSB; PJP2; UTP; KLIA; KLCC, TEC; more than 20 other COGEN projects: tender/studies/proposal**

PROJECT DIRECTOR



Nationality: Malaysian

Achievements:

- Reg. Professional Engineer
- Member of The Institution of Engineers Malaysia
- Chartered Electrical Engineer (UK)

Education: Brighton College of Technology, UK
B. Sc. (Hons) in Electrical Engineering -
1968

Name: Ir. Yahya Bin Abdul Ghani

Summary:

- ❖ **Experience: 48 Years**
- ❖ **Discipline: Electrical Engineering**
- ❖ **Type of Project: Power Plant, Cogeneration & Renewable Energy**
- ❖ **System: Generation (GAS, STEAM, OIL & HYDRO STATION);**
- ❖ **Extensive experience in Power Generation Technology**
- ❖ **Served as Operation & Maintenance Engineer/Manager and Project Engineer/Project Manager with TNB since 1968 till 1999.**
- ❖ **Involved as Project Director or Project Manager for major power generation projects internationally**

REEEP GROUP SDN. BHD. – GROUP ADVISOR



Nationality: Malaysian

Achievements:

- Competent Electrical Engineer (275kV)
- Registered Electrical Energy Manager
- Professional Engineer
- Member of The Institution of Engineers Malaysia (IEM)
- Secretary of Electrical Engineering Technical Division, IEM

Education: University of Malaya,

Degree: Bachelor of Engineer - 1977

Major: Electrical Engineering

Degree: Masters of Environment

Name: Ir. Francis Xavier Jacob

Executive Summary:

- ❖ **Experience: 45 Years**
- ❖ **Discipline: Electrical Engineering Services, Energy Management**
- ❖ **Type of Project: Commercial Building, Hospitals and Housing**
- ❖ **Regulatory aspects of Electrical Safety and Energy Efficiency**

REEEP GROUP S/B AVEFUME CONSULTANT



Nationality: Malaysian

Achievements:

- Registered Electrical Energy Manager (ST)
- Competent Steam & Internal Combustion Engineer Grade 1 (DOSH)
- Green Building Index (GBI) Facilitator
- Professional Engineer
- Honorary ASEAN Engineer
- Fellow member of The Institution of Engineers Malaysia
- Former Safety Auditor and Lead Auditor (ISO 9001) in TNB
- Expert in Energy Optimization (Steam, fan, Pump & EnMS) under UNIDO
- Certified Professional Measurement and Verification

Education:

Degree: in Mechanical Engineering (IEM Part 1 & 2)
Master in Engineering Management Energy (UNITEN & HEC Canada)

Name: Ir. LUK Chau Beng

Executive Summary:

- ❖ **Experience: 37 Years**
- ❖ **Discipline: Mechanical & Power Plant Engineering Services**
- ❖ **Experience:**
- ❖ **O&M in Thermal & Open Cycle Gas Turbine including engineering, safety & environment, reliability, project management and performance Commercial Building and Housing Development**
- ❖ **Building Audit for Cold & Hot water Services and Sanitary for Architect Center**
- ❖ **Consultant for Boiler & Thermal Energy Efficiency for local Boiler Manufacturer & government**
- ❖ **Trainer & Auditor for Boiler and Energy System Optimisation for industry, professional institution and University**

PROJECT DIRECTOR - Project Management, Civil; Structure & Architecture Work



Nationality: Malaysian

Achievements:

- Diploma in Building Technology, TARC
- Associates Member of Chartered Institute of Building, UK.
- Member of Chartered Institute of Building, Malaysia.

Education: Tunku Abdul Rahman College

Diploma: Building Technology - 1978

Major: Construction Management

Name: LIM KIM TEE

(DARJAT JELITA S/B)

Executive Summary:

- **Experience: 42 Years**
- **Discipline: Civil and Structural**
- **Type of Project: Cogeneration/District Cooling Plant, Factory, Hotel, Commercial Building, Infrastructures, STP, Reservoir and Residential Development**
- **System: Reinforced Concrete, Structural Steel, All types of Piling, Precast, Basement,**
- **COGEN Projects: PFK; PPMSB; PJP2; UTP; KLCC; more than 10 other COGEN projects: tender/studies/proposal**

PROJECT DIRECTOR - ELECTRICAL SERVICES



Nationality: Malaysian

Achievements:

- Competent Electrical Engineer (up to 275kV)
- Professional Engineer Board of Engineers, Malaysia
- Member of The Institution of Engineers Malaysia

Education: University of Malaya,
Bachelor of Engineering (Hons) - 1972
Discipline - Electrical

Name: Ir. Ong Song Kuan

(NITRO VENUS S/B - Director)

Executive Summary:

- ❖ **Experience: 48 Years**
- ❖ **Discipline: Electrical Engineering Services**
- ❖ **Type of Projects: Factory, Department Store, Hotel, Commercial Building, Recreational and Housing Development**
- ❖ **System: High and Low Voltage Distribution Systems, Building Services and Extra Low Voltage Services, Electrical Earthing System**
- ❖ **System Studies: Electrical Distribution and Protection Studies and Analysis**
- ❖ **Special Services: Value Engineering Services, Competent Control Services in compliance with Suruhanjaya Tenaga and assisting Clients to resolve TNB issues.**

Mr. LAI WAH -- ENGINEERING MANAGER

QUALIFICATION

CITY & GUILDS OF LONDON INSTITUTE, FULL TECHNOLOGY CERTIFICATE IN ELECTRICAL ENGINEERING PRACTICE

CERTIFICATE OF COMPETENCY CHARGEMAN B4, 33KV

CERTIFICATE OF COMPETENCY WIREMAN PW3

PASS PETRONAS 1ST TPCP INSTRUMENT STAFF ENGINEER

EMPLOYMENT

MITSUI ENGINEERING & SHIPBUILDING Co Ltd (Malaysia) as Electrical & Instrument Engineer, 2010 October till date

REEPGROUP AS Project Engineering Manager on project basis

BRUNEI SHELL PETROLEUM AS SENIOR PROJECT ELECTRICAL & INSTRUMENT ENGINEER, 2008 May, to 2010 May

MITSUI ENGINEERING & SHIPBUILDING Co Ltd (Saudi Aramco) as Instrument Specialist, 2007 December to 2008 April

PPMSB as Instrument Superintendent 2005 August to 2006 July

PPMSB as Instrument Supervisor 1994 August to 2005 July

PPMSB as Electrical Supervisor 1993 March to 1994 July

PPTSB as Electrical & Instrument Executive 1991 March to 1993 February

ABF as Electrical Supervisor 1985 May to 1991 February

PROCESS, ELECTRICAL, INSTRUMENT TECHNOLOGY

SWEET CRUDE OIL REFINERY PROCESS ENGINEERING, PROCESS OPERATION, INSTRUMENT & CONTROL

SOUR CRUDE OIL PROCESS ENGINEERING, PROCESS OPERATION, INSTRUMENT & CONTROL

CRUDE OIL PRODUCTION PROCESS, PROCESS OPERATION, INSTRUMENT & CONTROL

AMMONIA PLANT PROCESS ENGINEERING, PROCESS OPERATION, INSTRUMENT & CONTROL

LNG PLANT PROCESS ENGINEERING, PROCESS OPERATION, INSTRUMENT & CONTROL

COGEN PLANT PROCESS ENGINEERING, PROCESS OPERATION, INSTRUMENT & CONTROL

MONO ETHYLENE PLANT PROCESS ENGINEERING, PROCESS OPERATION, INSTRUMENT & CONTROL

GAS TURBINE & STEAM TURBINE ENGINEERING, OPERATION AND INSTRUMENT & CONTROL



4 Major Project Reference of The Team

List of Project Undertaken Pertaining High Voltage Project of Team Members

ITEM	PROJECT Information	INVOLVEMENT OF THE WORK			VOLTAGE (System Involved)
		Contract	Develop Switching Procedure	Operation and Maintenance Involvement	
1	Sultan Ismail Power Station, 900MW Combined Cycle Power Plant	Staff	Yes	Yes	275kV and etc
2	Sultan Iskandar Power Station, 2x120MW Oil Fired Power Station	Staff	Yes	Yes	132kV and etc
3	Sultan Saianuddin Abdul AZIZ Power Station, Phase II 2x300MW and Phase III 2x500MW Coal/Oil/Gas Fired Thermal Power Plant	Staff	Yes	Yes	275kV and etc
4	300MW Hulu Terengganu Hydro Power Plant	Staff	Yes	Yes	275kV and etc
5	IOI ACIDCHEM, Penang	Sub-EPCC (Elec)	Yes	Yes	33kV & 11kV
6	KANEKA, Gebeng, Pahang	Consultant / Contracting	Yes	Yes	132kV & 11kV
7	TOP GLOVE, Klang, Selangor	Consultant / Contracting	Yes	Yes	5 Plants, 33kV(TNB), 11kV & LV
8	PF(K)SB Cogeneration, Gurun, Kedah	Consultant / Resident Engineer	Yes	Yes	132kV, 11kV, LV
9	PPMSB Cogeneration, Sugai Udang, Melaka	Consultant / Contracting	Yes	Yes	132kV, 33kV, 11kV, LV
10	PJP2 Cogeneration, Putrajaya	Consultant	Yes	Yes	33kV, 11kV, 3.3kV, LV
11	Vale Malaysia Minerals Sdn Bhd, Perak => Transformer Oil Leak Rectification	Consultant / Contracting	Yes	Yes	275kV, 33kV, 6.6kV, LV

Project Experience of REEEP GROUP SDN BHD

PROJECT TITLE / DESCRIPTION	END USER/CLIENT
ELECTRICAL NETWORK STUDIES – B11 Platform 1.) Load Flow Study 2.) Short Circuit Study 3.) Motor Starting Study 4.) Load Shedding Study 5.) Arc Flash Study 6.) Protection Coordination Study	✓ PETRONAS CARIGALI SDN BHD
ELECTRICAL PLANT AUDIT, RELIABILITY STUDIES AND NETWORK STUDIES – Bintulu Integrate Facility (BIF) and Bintulu Crude Oil Terminal (BCOT). 1.) Load Flow Study 2.) Short Circuit Study 3.) Protection Coordination Study 4.) Electrical Plant Audit 5.) Reliability Improvement	✓ PETRONAS CARIGALI SDN BHD

Project Experience of REEEP GROUP SDN BHD

PROJECT TITLE / DESCRIPTION	END USER/CLIENT
<p>TWO UNITS OF 1,400kW (TOTAL: 2,800kW) GAS TURBINE COGENERATION SYSTEM FOR SDP GLOBAL AT TANJUNG LANGSAT, JOHOR</p> <ul style="list-style-type: none"> - ST/TNB Liaison Consultant - COGEN License Application - Network Studies 	<p>SDP GLOBAL (MALAYSIA) SDN. BHD.</p>
<p>Electricity Regulation 60: Competent Person Electricity Regulation 62: Competent Person on each Shift</p> <ul style="list-style-type: none"> - 275kV Compètent Résident Engineer 	<p>VALE MALAYSIA MINERALS SDN. BHD.</p>
<p>EFFICIENT MANAGEMENT OF ELECTRICAL ENERGY REGULATIONS 2008, ELECTRICITY SUPPLY ACT 1990 - Energy Manager</p>	<p>JOHNSON-JOHNSON SDN. BHD. VALE MALAYSIA MINERALS SDN. BHD.</p>
<p>Electricity Regulation 67.(2): Regular Inspection by Competent Engineer</p> <ul style="list-style-type: none"> - Periodic Inspection on Electrical Installation 	<p>IOI ACIDCHEM SDN. BHD. UG GLOBAL RESOURCES SDN. BHD. IOI ESTERCHEM (M) SDN. BHD.</p>

Project Experience of REEEP GROUP SDN BHD

PROJECT TITLE / DESCRIPTION	END USER/CLIENT
ONE UNIT 6.5MW GAS TURBINE COGENERATION SYSTEM FOR ACIDCHEM AT PRAI, PENANG - General Consultation	IOI ACIDCHEM SDN. BHD. (formerly known as ACIDCHEM INTERNATIONAL SDN. BHD.)
33.5MW GAS TURBINE COGENERATION SYSTEM FOR TORAY INDUSTRIAL COMPLEX AT PRAI, PENANG - COGEN License Application	Licensee: GAS MALAYSIA ENERGY ADVANCE SDN. BHD.
Compliance to DOSH Requirement for Reporting - Periodic Inspection on Internal Combustion Engine	IOI ACIDCHEM SDN. BHD.
In-house Training - Steam System & Internal Combustion Engine - ISO 50001 Energy Management System	IOI ACIDCHEM SDN. BHD. (February-2016, March-2016)

Project Experience of REEEP GROUP SDN BHD

PROJECT TITLE / DESCRIPTION	END USER/CLIENT
250 MWe Power Plant Proposal for MEC, Yangon, Myanmar. Proposal Design Package	MYANMAR ECONOMIC CORPORATION / GON PYAUNG TUN Co., Ltd. + MA HUP SENG ENG. SDN. BHD.
KGA New Office and Overhaul Facility Project. - General Consultation	KAWASAKI GAS TURBINE ASIA SDN. BHD.
TOKUYAMA MALAYSIA POLYCRYSTALLINE SILICON MANUFACTURING PLANT, SAMALAJU INDUSTRIAL PARK, BINTULU	Client: Z Aidun-Leeng SDN. BHD. Subcontract on the HVAC Control System Design
Engineering, Procurement, Construction and Commissioning (EPCC) of MLNG New Boiler Project - Support for bidding exercise	MALAYSIA LNG SDN. BHD. / PROACTIVE MH SDN. BHD.
ENGINEERING, PROCUREMENT, CONSTRUCTION & COMMISSIONING (EPCC) OF COGENERATION PLANT AT GPP A AND GPP B - Support for bidding exercise	PETRONAS GAS BERHAD / DELCOM SERVICES SDN. BHD.

Project Experience of REEEP GROUP SDN BHD

PROJECT TITLE / DESCRIPTION	END USER/CLIENT
<p>TOP GLOVE FACTORIES (No.3 , 10, 11, 22 and 25) ENERGY CONSERVATION PROJECT FOR THE EPCC OF GAS ENGINE COMBINED HEAT POWER COGENERATION SYSTEM</p> <ul style="list-style-type: none">- General Consultation- Electrical Engineering Support <p><i>Note: Five CHP Projects</i></p>	<p>TOP GLOVE SDN. BHD. / GMP MEDICARE SDN. BHD.</p>
<p>PROPOSED UPGRADING MAIN INTAKE ELECTRICITY SUPPLY FROM 11kV TO 132kV PROJECT FOR KANEKA (MALAYSIA) SDN. BHD.</p> <ul style="list-style-type: none">- General Consultation- Electrical Engineering Support	<p>KANEKA (MALAYSIA) SDN. BHD.</p>



5

Other Project Experience

Major Project-1: PP(M)SB COGEN Plant - Main Equipments

Five x 25MW GTG

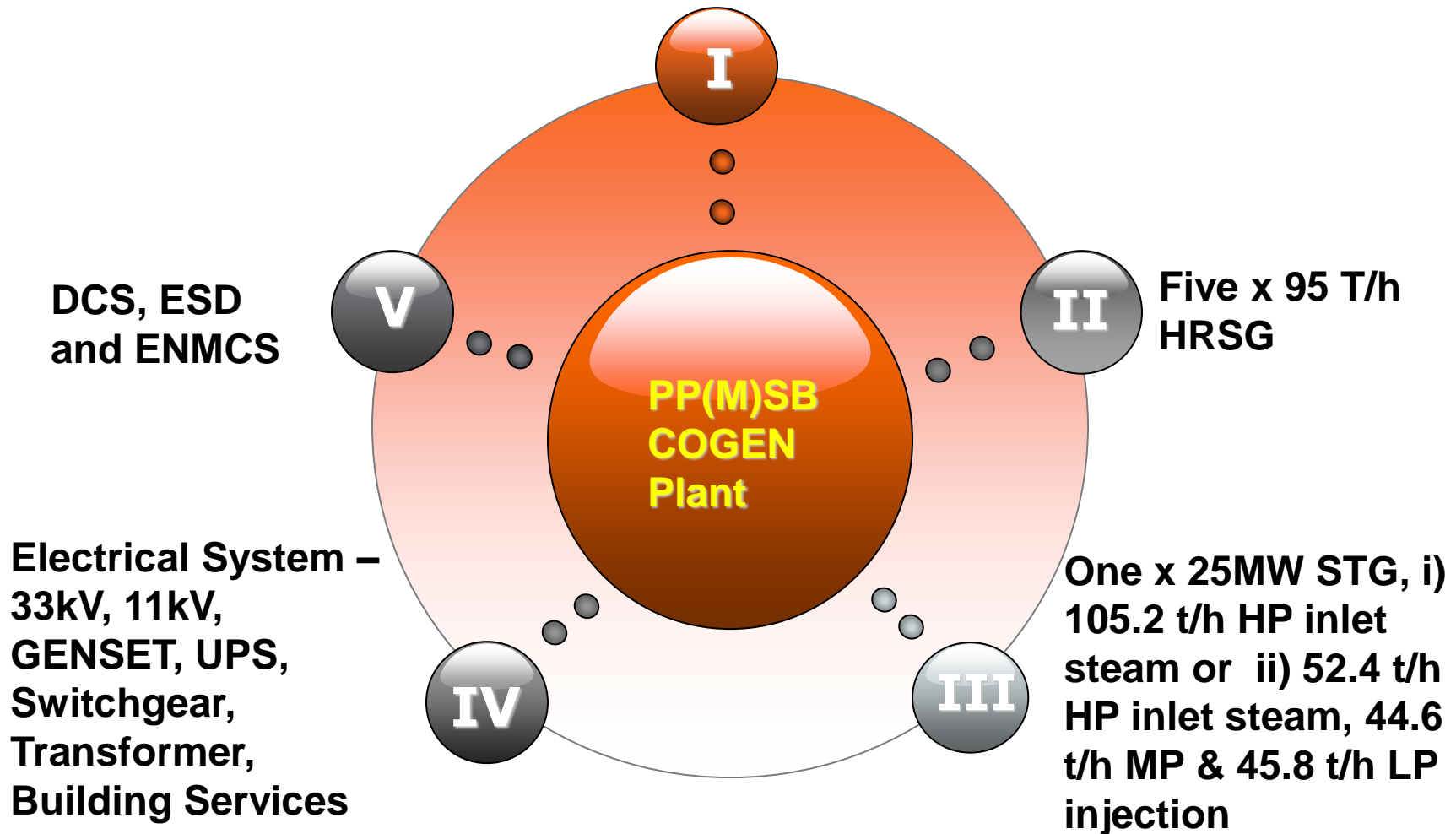

Major Project-1: PP(M)SB COGEN Plant - Plant Overview



Major Project-1: PP(M)SB COGEN Plant - Simplified Electrical Network

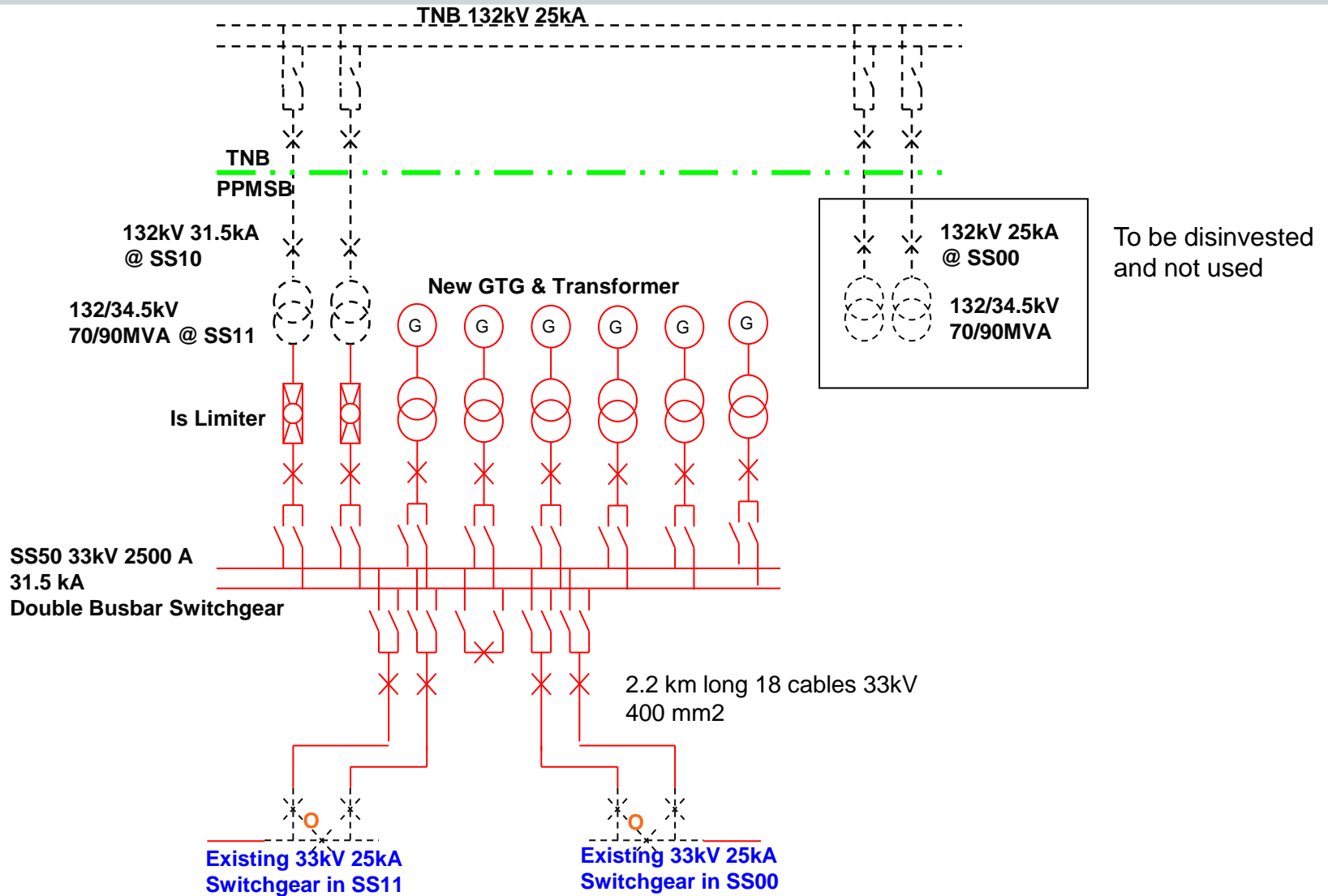

Major Project-3: COGEN/DCP Putrajaya Precinct 2



Cogeneration/District Cooling Plant Project, Putrajaya Precinct 2 (Core Island), Stage 2, 3 & 4.

Service Period:

November 2003 – April 2005

Project Value:

About RM300 million

Reference:

Mr. Wong Kar Ken, Tel No.: 03-8068 8282

Mr. Lo Chee Kheong, Tel No.: 03-8068 8280



Major Project-4: SIME DARBY INDUSTRIAL SDN. BHD.



RENEWAL APPLICATION FOR COGENERATION LICENCE for KOMPLEK KEJURUTERAAN TRACTORS, PUCHONG, SELANGOR D.E.

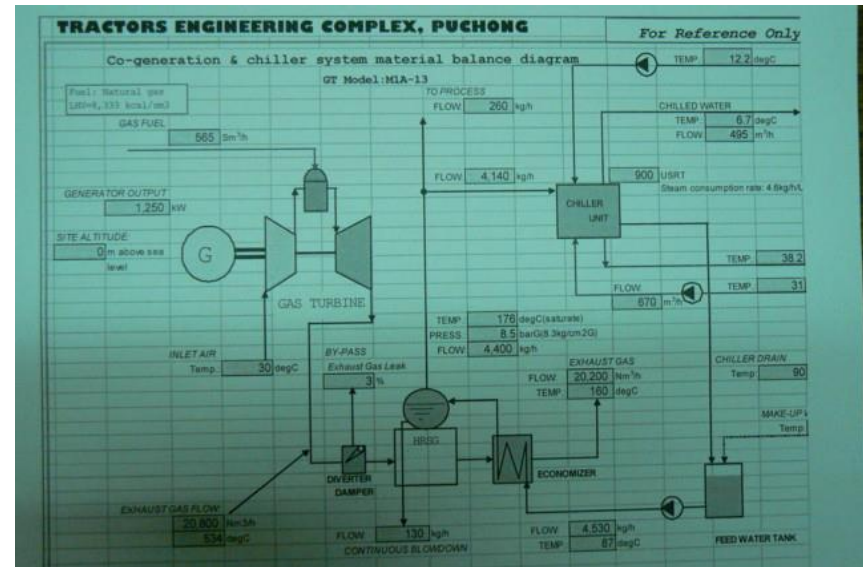

Other Project Experience of Team Member

PROJECT TITLE / DESCRIPTION	END USER
ONE UNIT 6.5MW GAS TURBINE COGENERATION SYSTEM FOR ACIDCHEM AT PRAI, PENANG - Sub-EPCC of Electrical System	IOI ACIDCHEM SDN. BHD.
PP(M)SB Cogeneration Project and COGEN Expansion Project	✓ Petronas Penapisan (Melaka) Sdn Bhd
Plant Debottlenecking Project EPCC of Gas Turbine Cogeneration System	✓ Petronas Fertilizer (Kedah) Sdn Bhd
PROPOSED KR-1 Waste Water Treatment Plant Upgrade - Stage 1A	✓ Petronas Penapisan (Terengganu) Sdn Bhd
Engineering, Procurement, Installation and Commissioning (EPIC) of HRSG Boiler at Kertih Compressor Station in GPP Complex A, Kertih	✓ PETRONAS GAS BERHAD
Cogeneration/District Cooling Plant Project, Putrajaya Precinct 2 (Core Island), Stage 2, 3 & 4.	✓ Gas District Cooling (Putrajaya) Sdn Bhd
MELAKA PAHLAWAN POWER PLANT 2x148MVA GTGs and 1x146MVA STG - Electrical Network Study	PAHLAWAN POWER SDN BHD (467847-U) (Wholly-owned subsidiary of Powertek Berhad)

Other Project Experience of Team Member

PROJECT TITLE / DESCRIPTION	END USER/MAIN CONTRACTOR
Sultan Ismail Power Station, 900MW Combined Cycle Power Plant	✓ TENAGA NASIONAL BERHAD
Sultan Iskandar Power Station, 2x120MW Oil Fired Power Station	✓ TENAGA NASIONAL BERHAD
Sultan Ismail Power Station, 1x30MW Oil Fired Power Station (Final Extension)	✓ TENAGA NASIONAL BERHAD
Sultan Salahuddin Abdul Aziz Power Station, Phase II 2x300MW and Phase III 2x500MW Coal/Oil/Gas Fired Thermal Power Plant	✓ KAPAR ENERGY VENTURES
300MW Hulu Terengganu Hydro Power Plant	✓ TENAGA NASIONAL BERHAD
Advisory Service for 3000MW Coal Fired Mine Mouth Power Plant Project in Pranap, Riau, Indonesia.	✓ Transpower Link Sdn. Bhd.
2x110MW Combined Cycle Power Plant Rehabilitation in Yangon, Myanmar.	✓ Consortium of Transturbo & Equator Engineering Sdn. Bhd.

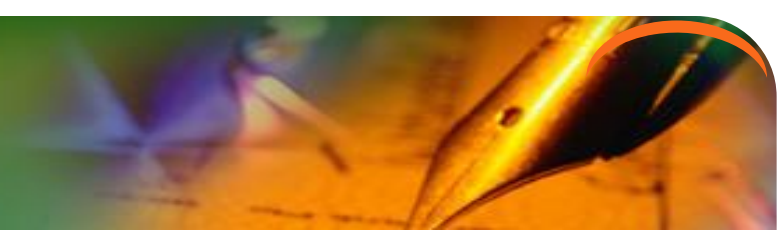

THANK YOU



E-mail Address: reeepgroup@gmail.com
E-mail Address: enquiry@reeepgroup.com
Website: www.reeepgroup.com

Contents



6

REEEP Control And Automation

ENERGY COMMISSION – Registered Electrical Contractor



BORANG U
(peraturan 92)

AKTA BEKALAN ELEKTRIK 1990

**PERAKUAN PENDAFTARAN SEBAGAI
PENGILANG PAPAN SUIS**

Mengikut peraturan 92 Peraturan-Peraturan Elektrik 1994, Perakuan ini dikeluarkan kepada

REEEP CONTROL AND AUTOMATION SDN BHD
(nama syarikat)

dan memberi kuasa kepada pemegang untuk menjalankan perniagaan mengilang papan suis pada voltan pengendalian lebih kurang :



*kilovolt

sebagai Pengilang Papan Suis di :

**NO. 2A, JALAN 5/1
TAMAN INDUSTRY SELESA JAYA
43300 BALAKONG
SELANGOR**

(alamat syarikat, firma dan cawangan)

selama tempoh 5 tahun** dari tarikh dikeluarkan yang ditunjukkan di bawah :

Tarikh dikeluarkan : 30/12/2017

Tarikh Habis Tempoh : 29/12/2022

No. Pendaftaran : ST(TKL)SGR/C/PPS/00167/2017

FIRMA : 1,980.00

Ir. MD-RASHID BIN ABDULLAH
Pengarah Kawasan
Suruhanjaya Tenaga
Kawasan Suruhanjaya Tenaga (Kuala Lumpur)

** Tidak kurang daripada satu tahun dan tidak lebih daripada lima tahun.

Company Brief



REEEP CONTROL AND AUTOMATION SDN. BHD. was incorporated on 11-11-11 by a team of energetic and experienced engineers. The company commits to provide a reliable, quality and safe work to clients.

REEEP is an acronym of **RENEWABLE ENERGY AND ENERGY EFFICIENCY PARTNERSHIP**. The company welcomes any corporation, company, energetic and experienced engineers to be partnering with us to form an integrated all-in-one business related with **electrical, control and automation industry**. The range of business includes product, system, project, engineering, installation & commissioning, training, operation and maintenance.

REEEP CONTROL AND AUTOMATION SDN. BHD. is associated with REEEP GROUP SDN. BHD.. The objective is to extend the integrated all-in-one services and business.

Panel Experience

PROJECT TITLE	DESCRIPTION
SUBCONTRACTING WORK	Panel Fabrication <ul style="list-style-type: none">- Sub-switch Board c/w Power Factor Regulator and capacitor bank- Distribution Board- Metering Panel
INTERNAL PROJECT	Panel Fabrication <ul style="list-style-type: none">- Motor Control Center- System Control Panel- Distribution Board

Project Experience

PROJECT TITLE / DESCRIPTION	ULTIMATE OWNER / CLIENT
<p>KOSSAN RUBBER ENERGY CONSERVATION PROJECT - MOTOR CONTROL CENTRE OF GAS ENGINE COMBINED HEAT POWER COGENERATION SYSTEM</p> <ul style="list-style-type: none">- Design and Supply Control Panel for Heat Recovery System (MCC-COGEN): Three Sets- Cabling Work for MCC-COGEN outgoing circuits	<p>KOSSAN RUBBER INDUSTRIES BHD. / MACKENZINE INDUSTRIES SDN. BHD.</p>
<p>ONE UNIT 6.5MW GAS TURBINE COGENERATION SYSTEM FOR ACIDCHEM AT PRAI, PENANG</p> <ul style="list-style-type: none">- Design and Built Electrical System- Electrical Sub-contracting Work- Integrate the whole COMPLEX to be one network- Power Measurement of the Existing TNB Intake Supply (1 x 33kV and 2 x 11kV) => Generate Profiles (Voltage, Frequency, Power Factor, Power Demand, Energy Consumption); Report and Recommendation	<p>ACIDCHEM INTERNATIONAL SDN. BHD. / SIME DARBY OFFSHORE ENGINEERING SDN. BHD.</p>

Project Experience

PROJECT TITLE / DESCRIPTION	ULTIMATE OWNER / CLIENT
<p>TOP GLOVE FACTORIES (No.3, 22 and 25) ENERGY CONSERVATION PROJECT FOR THE EPCC OF GAS ENGINE COMBINED HEAT POWER COGENERATION SYSTEM</p> <ul style="list-style-type: none">- Design and Supply Control Panel for Heat Recovery System (MCC-COGEN)	<p>TOP GLOVE SDN. BHD. / MACKENZINE INDUSTRIES SDN. BHD</p>
<p>UP KEEPING WORK</p> <ul style="list-style-type: none">- Rectification work of capacitor bank- Technical Audit of Electrical Installation- Cabling Work and Network Diversion- Supply and Install Emergency light & Keluar Sign	<p>STANTA MAUSER (MALAYSIA) SDN. BHD.</p>
<p>TOP GLOVE FACTORIES (No.21, 22 and 25) ENERGY CONSERVATION PROJECT Re - SCADA for Electrical Network Monitoring and Control (TNB+ CHP System)</p>	<p>Client: GMP MEDICARE SDN. BHD.</p>

Project Experience

PROJECT TITLE / DESCRIPTION	ULTIMATE OWNER / CLIENT
PENANG AIRPORT EXPANSION - Technical Manpower Support (Supervisor)	CONSULTANT: ZAIDUN LEENG SDN. BHD.
PANASONIC PROJECT, KULIM - Technical Manpower Support (Senior Engineer)	CONTRACTOR: TEMACON ENGINEERING SDN. BHD.
Design And Built Additional Distribution System – Supply and Install 1600Amp 4P SSB – Supply and Install Submain Cable – Commissioning the system	Client: GMP MEDICARE SDN. BHD.
Design And Built Additional Distribution System – Asses Existing Faulty DC Charger System – Replace, Supply and Install New System – Commissioning the system	Client: - STANTA MAUSER (MALAYSIA) SDN. BHD. - GMP MEDICARE SDN. BHD. - TG MEDICAL SDN. BHD.

Project Experience



PROJECT TITLE / DESCRIPTION	ULTIMATE OWNER / CLIENT
TANJUNG BIN POWER PLANT WATER TREATMENT - Chemical Dosing skid Control Panels	Client: Prominent Fluid Control
BLUESCOPE STEEL DOLPHIN PROJECT - Electrical installation and cabling works	Client: Spektra Watertech

Trading Experience

PROJECT TITLE / DESCRIPTION	ULTIMATE OWNER / CLIENT	YEAR
<p><u>ADVANTECH PRODUCT</u></p> <ul style="list-style-type: none"> - Wedaccess (Centralized Control Programming Language) - Industrial Panel Computer with Touch Screen - Input / Output Module (Analogue and Digital) 	<p>Client:</p> <ul style="list-style-type: none"> - Internal Project Sale - DATACON INTEGRATION SDN. BHD. - etc 	<p>Since 2012 (on going sale)</p>
<p><u>ICT PRODUCT</u></p> <ul style="list-style-type: none"> - LENOVO Notebook - Autodesk AUTOCAD LT 2013 - ASUS Notebook - Acrobat PDF writer 	<p>Client:</p> <ul style="list-style-type: none"> - Internal Project Sale - PROFMECH ENGINEERING SDN. BHD. - Etc 	<p>Since 2012 (on going sale)</p>
<p><u>WAGO PRODUCT</u></p> <ul style="list-style-type: none"> - Programmable Logic Controller - Input / Output Module (Analogue and Digital) 	<p>Client:</p> <ul style="list-style-type: none"> - Internal Project Sale - DATACON INTEGRATION SDN. BHD. - etc 	<p>Since 2012 (on going sale)</p>

SENIOR ENGINEER – PROCESS & PIPING

Name: Mr. CHONG YAU YANG

Executive Summary:

- ❖ **Experience: 6 Years**
- ❖ **Discipline: Process & Piping**
- ❖ **Type of Projects: Power plant
Cogeneration Plant & Utilities Plant**
- ❖ **System: Piping, Pipe Stress,
Hydraulics, Steam/Water Process
Design & rotating equipment.**
- ❖ **Software competency:**
 - **AutoPIPE Pipe Stress analysis**
 - **Autocad**

Nationality: Malaysian

Professional Affiliations:

- Member of Board of Engineers Malaysia (BEM)

Education: Multimedia Universiti ,
B. Eng (Hons) in Mechanical Engineering- 2007

PERAKUAN PENDAFTARAN

Adalah dengan ini diperakui bahawa kontraktor yang dinyatakan di bawah ini telah berdaftar dengan Lembaga mengikut Bahagian VI Akta Lembaga Pembangunan Industri Pembinaan Malaysia 1994. Pendaftaran ini adalah tertakluk kepada syarat-syarat yang telah ditetapkan di belakang Perakuan ini

No Pendaftaran: 0120141201-SL160188

Nama Kontraktor : REEEP CONTROL AND AUTOMATION SDN. BHD.

Alamat Berdaftar : NO. 12A-1, JALAN RIMBUNAN RAYA
LAMAN RIMBUNAN KEPONG
52100 KUALA LUMPUR
WILAYAH PERSEKUTUAN

Gred, kategori dan pengkhususan berdaftar

G2 ME E04
G5 ME E05 E06 E10 E11 E15 E16 E17 E03 M15 E18 E19 E21 E22 E24
E32

Tarikh Mula Berkuatkuasa : 01 DEC 2015

Tarikh Habis Tempoh Perakuan : 30 NOV 2016*

**Perakuan ini hendaklah diperbaharui seawat-lewatnya 60 hari sebelum tarikh habis tempoh.*

STATUS : AKTIF - Kontraktor yang diawardkan projek semasa perakuan pendaftaran ini dikeluarkan.



HAJI RAZUKI BIN IBRAHIM
b.p. Ketua Eksekutif
Bertarikh: 09 NOV 2015